

GR-1D

Downflow Regenerate Control Valve

Installation, use and maintenance manual
(GR2-1D、GR4-1D、GR10-1D、GR10-1DS)



Scan Qr cord for the latest

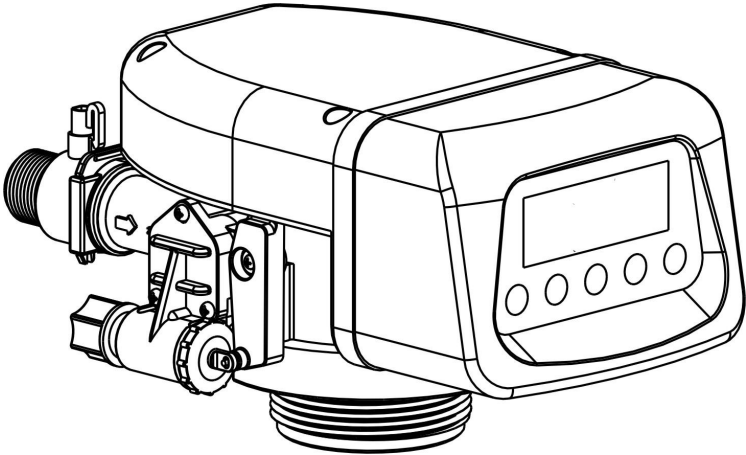

GR-1D shift animation



GR-1D install animation



GR10-1DS install animation

I . Operating Board

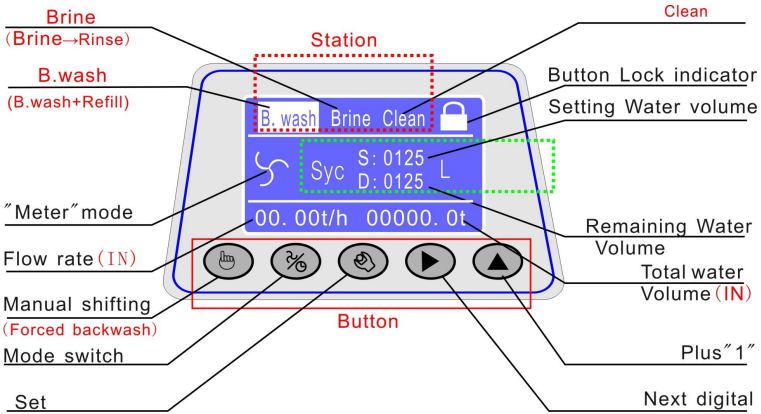

1、Instructions of the LCD display controller







Pic1: GR-1D LCD Screen

Flow mode "Syc" interface





	<p>B.wash+Refill</p> <p>S:0125: Setting water for backwash and Refill , measured by the inlet flow meter,</p> <p>D:0125:Decrementing State, Decrement to zero and switch to the next station ;</p> <p>00.00t/h: The current flow rate of inlet</p> <p>0000000t: Accumulative water amount of inlet</p>
	<p>Brine(Brine in → Rinse)</p> <p>S:0125: Setting water for Brine absorb and Rinse, measured by the inlet flow meter, it is amount of water passing through the ejector</p> <p>D:0125:Decrementing State, Decrement to zero and switch to the next station ;</p>



	<p>Clean(Solenoid valve open)</p> <p>S:0125: Setting of Washing, measured by the inlet flow meter;</p> <p>D:0125: Decrementing State,Decrement to zero and switch to the next station;</p>
	<p>Soft (Softening)</p> <p>S:005.5: water volume of one cycle setting, measured by the inlet flow meter.unit:T</p> <p>D:005.5: Decrementing State, to zero and switch to the next station</p>

Time mode  "interface



 <p>B.wash+Refill</p>	 <p>Brine(Brine→Rinse)</p>
 <p>Clean</p>	 <p>Soft</p>



The operation button:

: Manual button; : Parameter setting; : Mode Switch; : next; : plus 1

A、Unlock : Press and hold  &  simultaneously for one second ,Displaying . the operation button is unlocked.

B、Lock : After three minutes of inactivity, the operation button is automatically locked.

C、 Mode switch: When unlocked, pressing it switches between Time mode  and Meter mode .

- D、 **Manual** button: When unlocked, pressing it switches to the next station.
- E、 **Parameter setting**: When unlocked, pressing it display the interface to change parameter settings.
- F、 **Forced Backwash**: locked state, press **6 times** the valve shift to **B.wash** station.

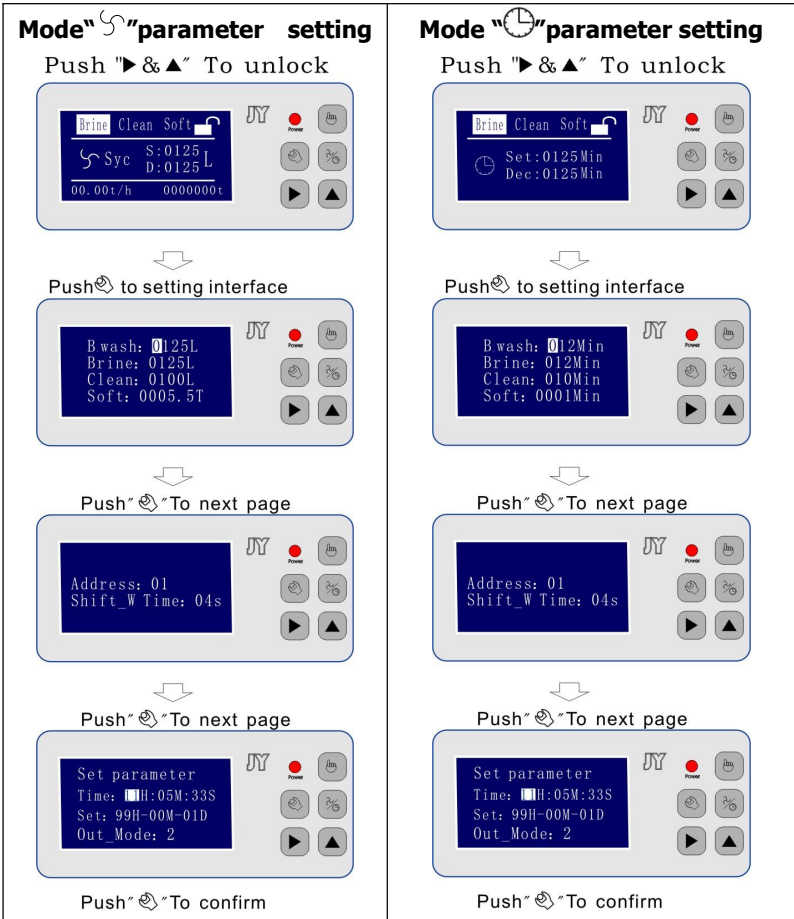

2、 LED Controller Operation instruction

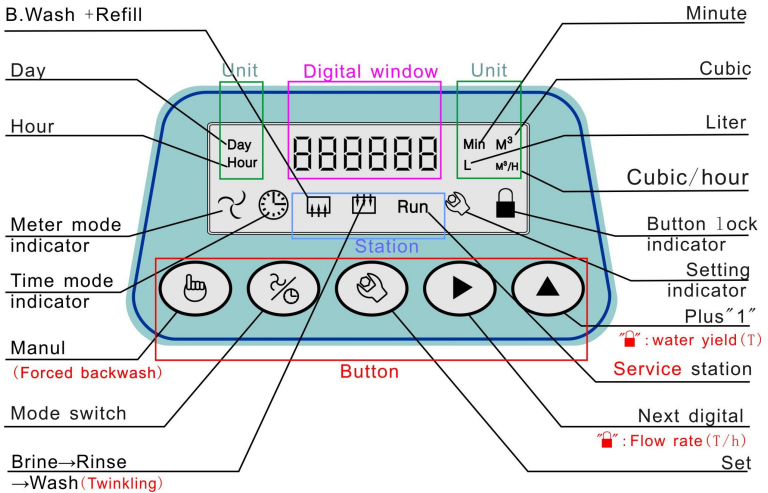

Pic2: GR-1D LED Screen

LED Display

Day \ hour \ min \ M³ \ L \ M³/H are the units of time or flow, respectively, with the content, as suggested by the highlighted display

☺: Meter mode symbol

🕒: Time mode symbol

🚰: **B.wash+Refill**

🚰: **Brine→Rinse→Wash(Twinkle)**

Run: Soft

👉: Enter to the setting status indicator

🔒: Buttons locked indicator

Button:

Name:

👉:

Manual button: Unlock state, press it the valve shifting to next station

Forced Backwash: Lock state,press it 6 times the valve shifting to

B.wash

: Parameter Set

: Mode switch

 : Next

: Plus 1

Setting the defined parameters

C1: Meter Mode, Setting water for Brine sucking and Rinse water. Unit: L

C2: Meter Mode,Setting water of **Wash**. Unit: L

C3: Meter Mode, Setting Softening water quantity of one cycle. Unit: m³

CO: Meter mode:setting water volume for **B.wash+Refill**.unit:L

C4: Time mode: Setting **Brine** sucking and **Rinse** time. Unit: Min

C5: Time mode: Setting **Wash** water time. Unit: Min

C6: Time mode: Setting Softening time of one cycle. Unit: Min

CP: Time mode:setting time for **B.wash+Refill**.unit:Min

C7: Hour clock setting 0-23(Hours)

C8 Minute clock setting 0-59(Minutes)

C9 Delay Regeneration 0-23. if the valve is in servicing and can not switch to regenerate.it can be take delay regeneration.set a day any 0-23 hour , set 99 is to cancel this function.

CF: When the delay regenerate is enabled, If you want to take days as the unit of time; Regenerate once per set number of days. To achieve daily regeneration, set parameter C6 not more than one day (1440 minutes)

CC: Relay output control mode , set the mode 0, 1, 2, 3, 4, 5, 6 in the following table(page:9).

CL: Number of regeneration: Such as setting "2", the program will realize

 and  twice one cycle ;

CD: 485 Communication address

(1)、Working station parameter

	<p>🔓: Meter mode</p> <p>🏠: Station: Wash</p> <p>C2-060: Station water volume is set as 60L. Alternately display the decrement state, decrement to zero and switch to the next station.</p>

(2)、Parameter setting (Flow mode example)

	<p>Simultaneously press the ▶ & ▲ buttons to unlock</p> <p>Press 🖐 to enter parameter setting interface</p> <p>Press ▲, plus 1 to change value of the digit.</p> <p>Press ▶ to confirm ,press it continue proceed to next C2、C3、CO.Nether to Set C4→CP to</p> <p>Press 🕒 to time mode.</p>
--	--

(3)、Flow rate and accumulative water quantity query

	<p>locked state 🗑</p> <p>Press ▶ to display the current flow rate of inlet .unit is M³/h</p>
	<p>locked state 🗑</p> <p>Press ▲ to display the accumulated water inlet, unit is M³</p>

II、Input/output control instructions

1、Interlock line connection as below

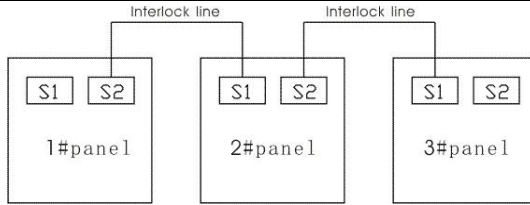

Pic3: Interlock

2. External control interface

In RUN station, The valve can be controlled into **Brine(III)** by the external other control system.

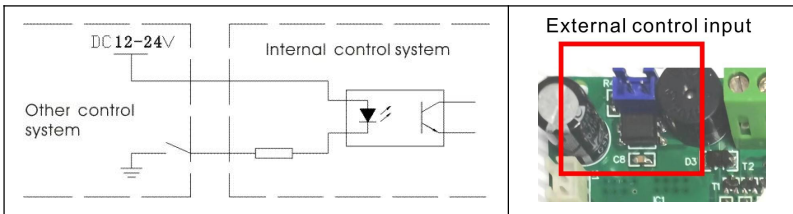





Pic4: External control input

3. Relay Output and mode set (CC)

- A. The contact capacity of the relay is 5A/250V.
 - B. Relay output port:
NO= normally open, **NC**=normally closed, **COM** = common
 - C. When connecting the output of the relay, the AC110V-220V power supply input end shall be connected with the leakage circuit breaker.
- In different modes, the relay outputs NO and COM, which is connected as "C", disconnected as "×"**

GR-1D Downflow Regen Control valve

Mode	 B.wash B.wash+Refill	 Brine Brine→Rinse	 (Twinkle) Clean	RUN Soft	Valve shifting
0	C	C	C	C	×
1	C	C	C	×	×
2	×	×	×	C	×
3	C	C	C	×	×
4	C	C	C	×	×
5	×	×	×	CX	×
6	C	×	×	×	×
7	C	C	C	×	C
8	×	×	×	×	C

Mode	Applications
0	Inlet Solenoid valve mode: Pressure relief during transposition, lever switch and feed pump control. Pic 5
1	Inlet pump mode: When its station is in  (B.wash+Refill) and  (Brine→Clean), Start the inlet booster pump
2	Outlet pump mode: For example, for subsequent RO high pressure pump start-stop control.
3	Tow valve one RUN & one standby mode: Interlock line connected. When one valve completes  (B.wash+Refill) and  (Brine→Rinse→clean) and switches to soft(Run) station, judge that if another valve is also in Run(Soft) station, the valve close its own inlet solenoid valve and wait for backup. As shown in figure 6.
4	Inlet solenoid valve double valve parallel interlock respectively backwash mode: Interlock line connection is required, this mode for filter valve use.
5	CX(Mode2 additional conditions) : When the inlet flow meter check the water flow signal in Soft station.the Relay is

	Connected.
6	Backwash booster and compressed air mode
7	Only in service, “NO” is open
8	Only in the valve shifting, “NO” is closed

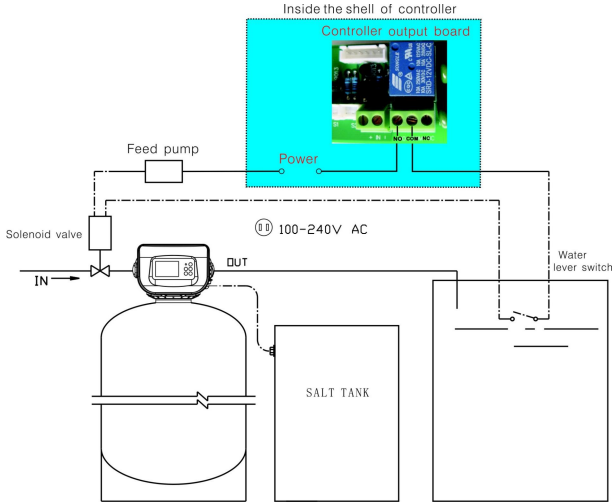

Pic5: Mode(0): Solenoid valve liquid level switch and feed pump

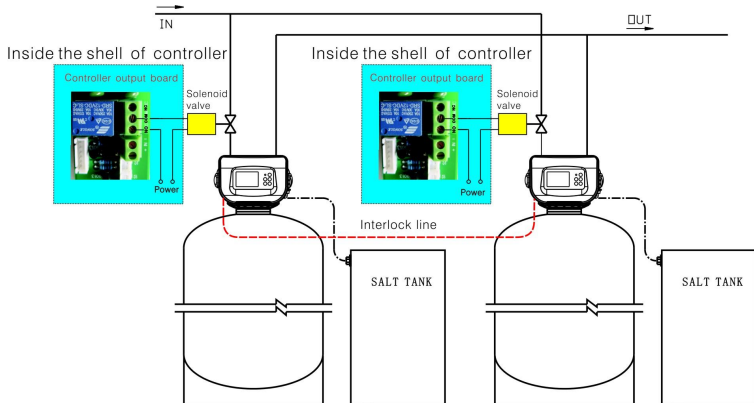

Pic6: Mode(3): Tow valve one RUN & one standby inlet water solenoid valve mode:

III、 Process

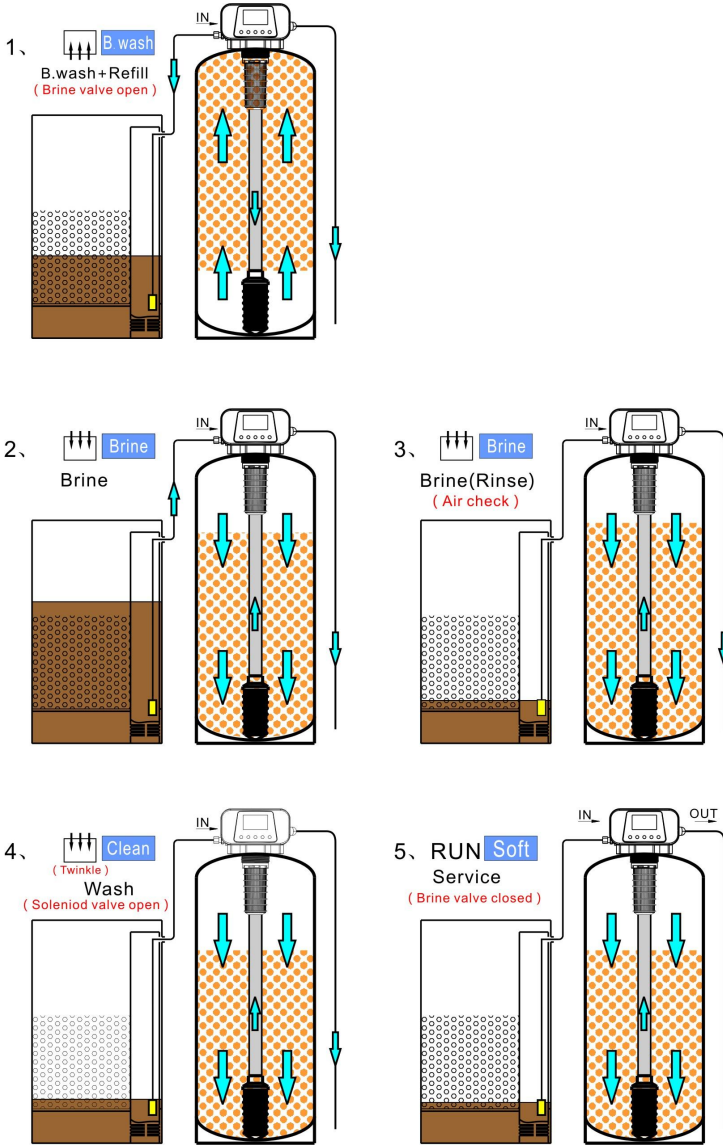

Pic7: GR-1D Downflow Regenerate flow process

IV Configuration, installation and raw water condition

1、 Using condition

- 1, If the raw water contains mechanical impurities of gel or powder, it is necessary to install sand filter, cloth bag or disc type functional filter, factory valve inlet filter can only ensure the occasional large particles into the valve body.
2. The volume of the salt tank is not less than the volume of the exchange tank.
- 3, Drainage pipe exports nearly flush with the ground, too high or too low will affect the equipment of Brine, Pipe must be mounted stable.
- 4, Water static pressure is 0.1~ 0.6 MPa. water temperature is 0°C~55°C .
- 5, the equipment is installed in the room, the humidity should not be too high, there should be no corrosive chemical gas around, to avoid strong electromagnetic interference to affect the power supply of the control valve.
6. Floor drain or trench drainage shall be set around the equipment to avoid accidental water leakage causing the floor and other indoor items to be flooded.

2、 Install air check valve

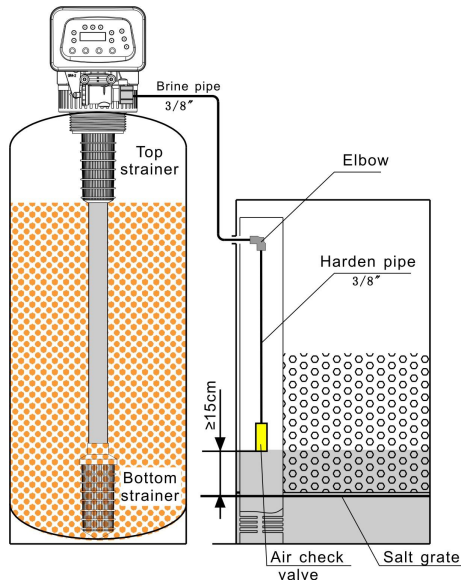

Pic8: GR-1D Install air check valve

3、 the valve geometry size

GR2-1D dimension drawing

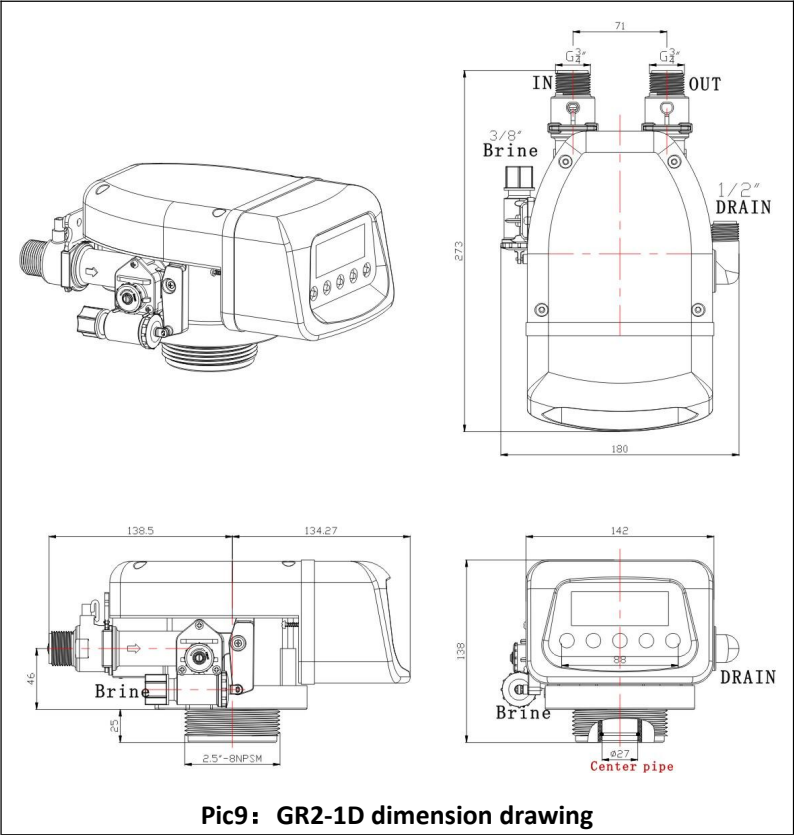

Pic9: GR2-1D dimension drawing

GR4-1D dimension drawing

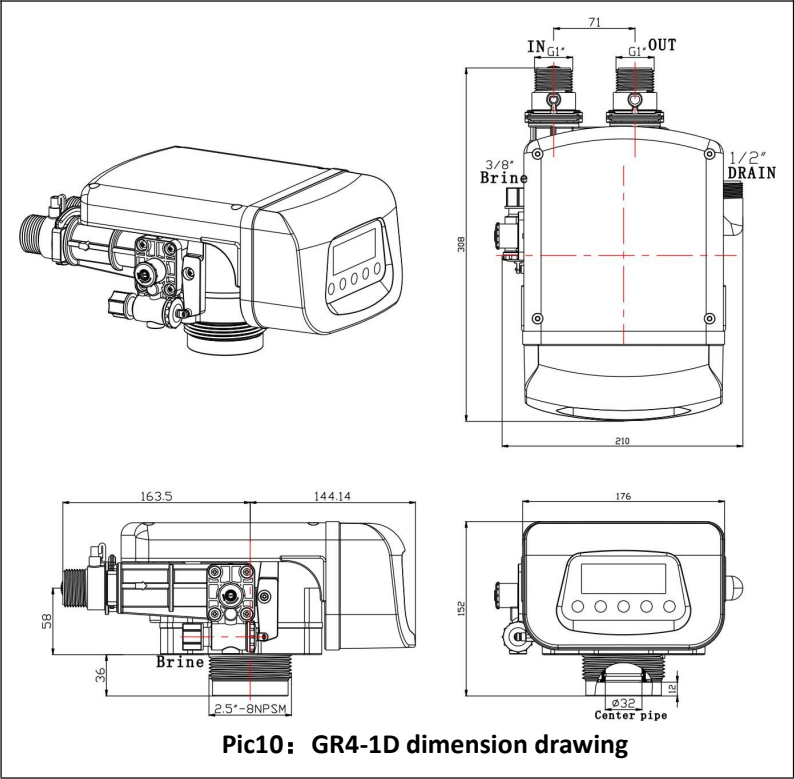

Pic10: GR4-1D dimension drawing

GR10-1D dimension drawing

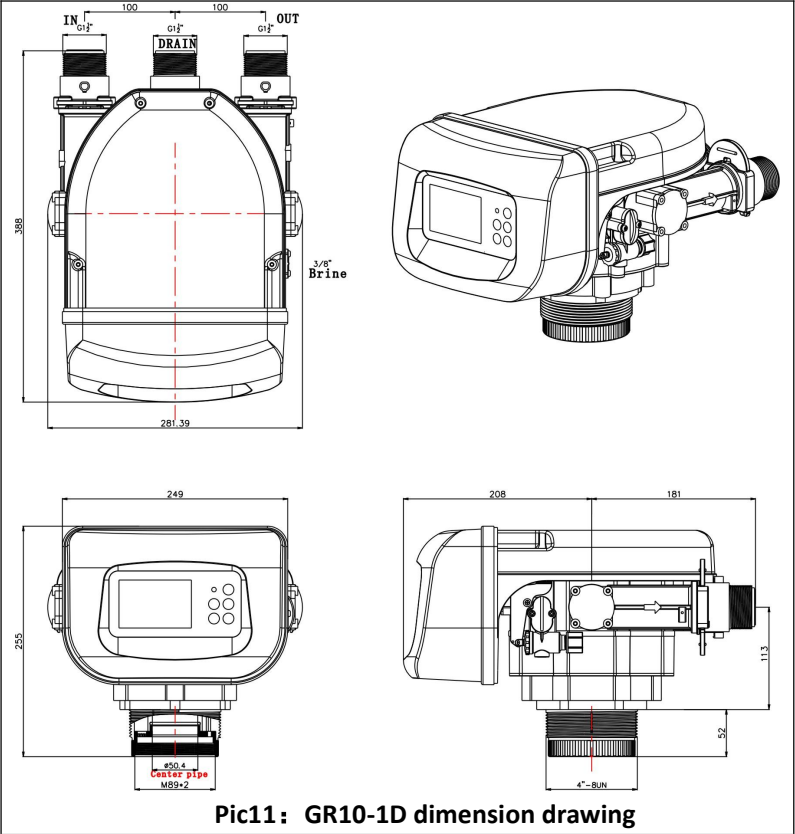

GR10-1DS dimension drawing

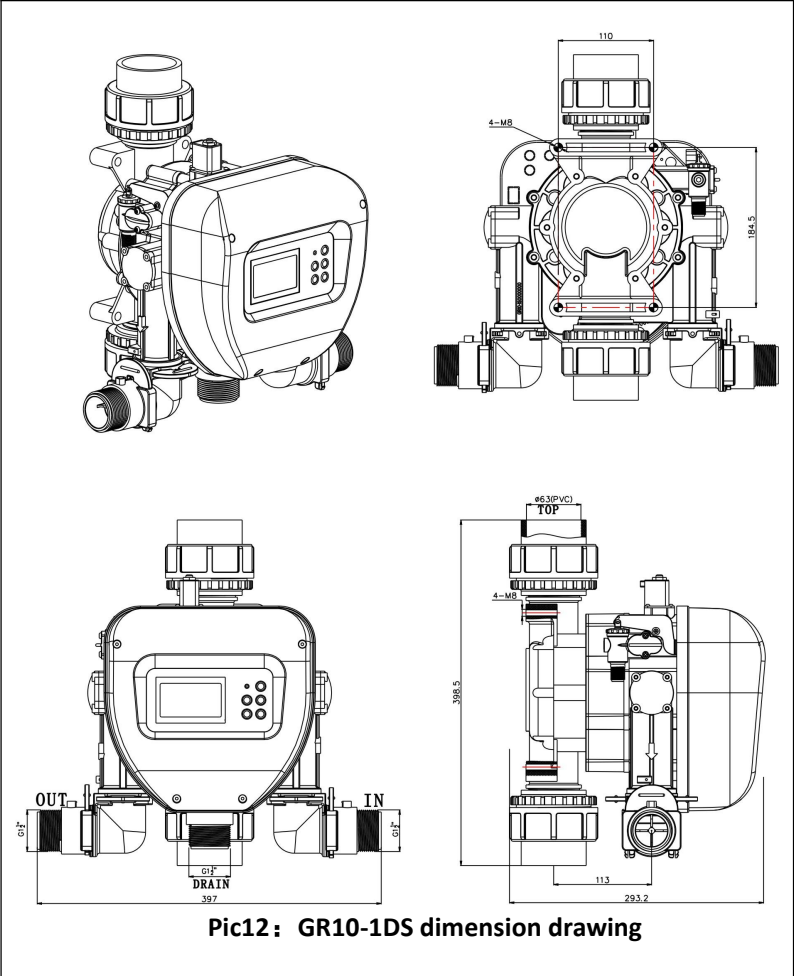

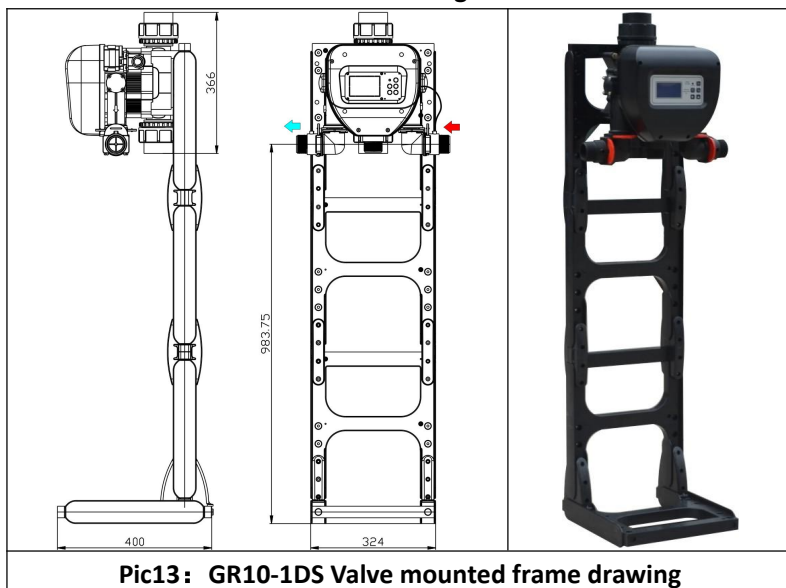

Pic12: GR10-1DS dimension drawing

GR10-1DS Valve mounted frame drawing



Pic13: GR10-1DS Valve mounted frame drawing

V. Configuration and setting

Describe	Display	Formula
Service	RUN (Soft) : T	$C3 = [\text{resin filling volume (L)} \times 90\%] \div \text{Raw water hardness (mmol/L)}$
Brine → Rinse	 (Brine) : L	$C1 = \text{Resin filling volume (L)} \times 250\% (50\% + 200\%)*$
Wash	 (Clean) : L	$C2 = \text{Resin filling volume (L)} \times 100\%$
B.wash+Refill	 (B.Wash) L	$C0 = \text{Resin filling volume (L)} \times 250\% (200\% + 50\%)**$

Note!

- 1 *The setting water refers to the process of jet injection quantity sum, including Brine Absorption 50% and Rinse 200%.*
- 2. **50% is the salt tank refill water and 200% is the B.wash water. This ratio is based on the valve body channel design and test. (50% means 1*

liter of pure brine regenerate 2 liters of resin).

3, Water hardness unit is **mmol/L**

4, Resin working exchange capacity calculating is 1000 mol/m^3 ;

5, Design and calculation of brine concentration is 16%(Dry salt tank dilution concentration) ;

6、1Liter brine(16%)Molar value= $1000\text{g} \times 16\%/58.8\text{g}(\text{NaCL}) \times 1.4(\text{Specific consumption}) \approx 160/80=2\text{mol}$

VI Mode choice

(1) Meter mode "  " (Default mode)

Under normal circumstances, should choose meter mode, the mode is not affected by the feed water pressure changes in equipment operation effect. Very important, the flow meter have water stop memory.

(2) Time mode "  " (standby mode)

When the water pressure is stable, instantaneous water yield stability, equipment according to user requirements can choose **Time mode**. If the flow meter is fault, you can switch to **Time mode** by the button  temporary.

VII. Curve of Flow and Pressure for the Valve

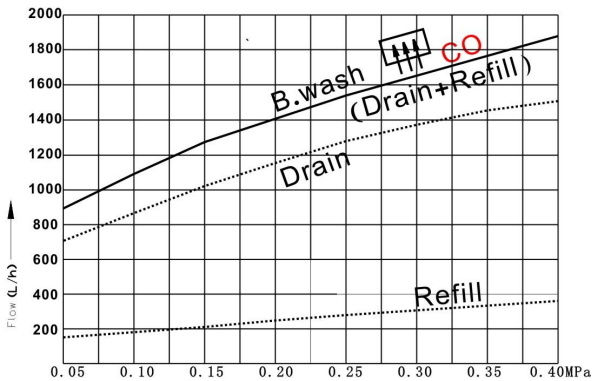
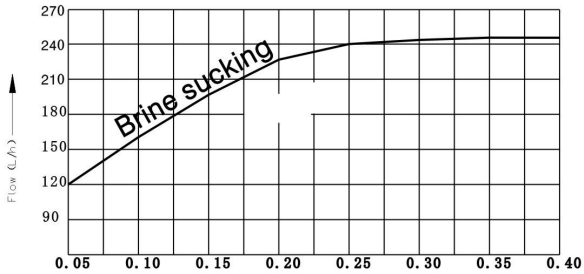
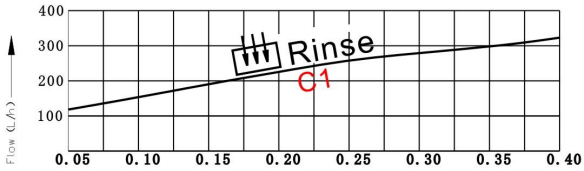
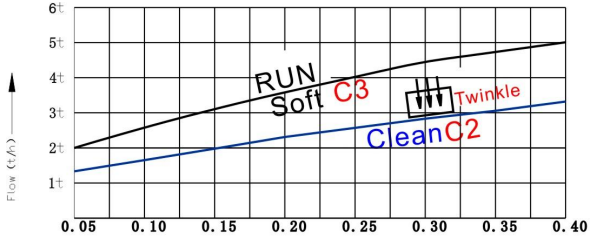

Pic14: GR-1D Curve of Flow and Pressure for the Valve

GR-1D Downflow Regen Control valve

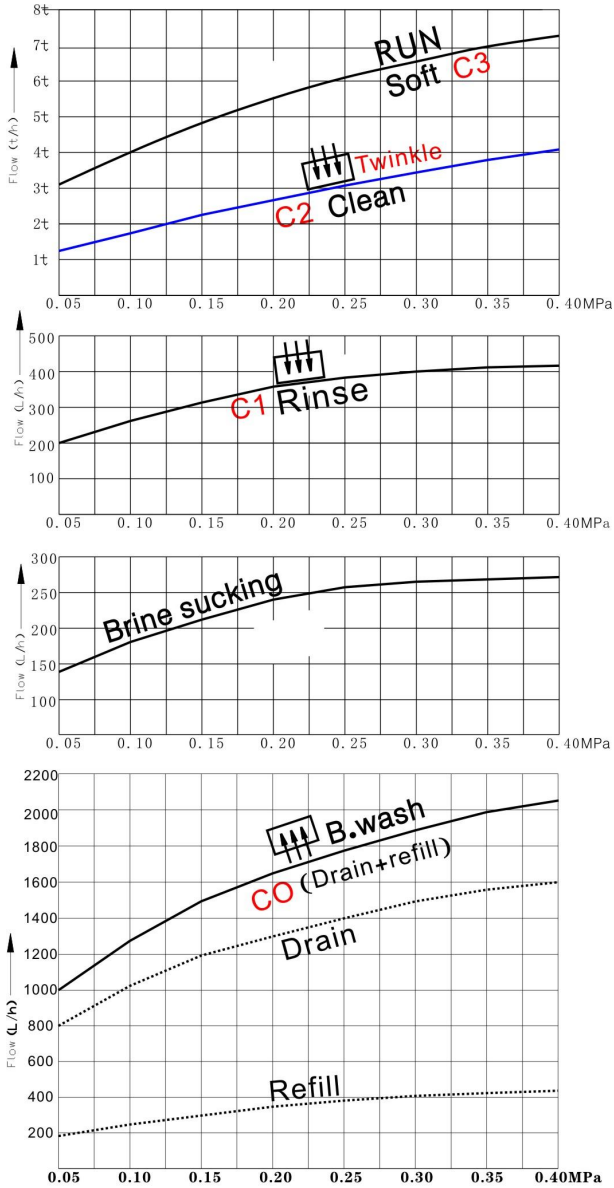

Pic15: GR4-1D Curve of Flow and Pressure for the Valve

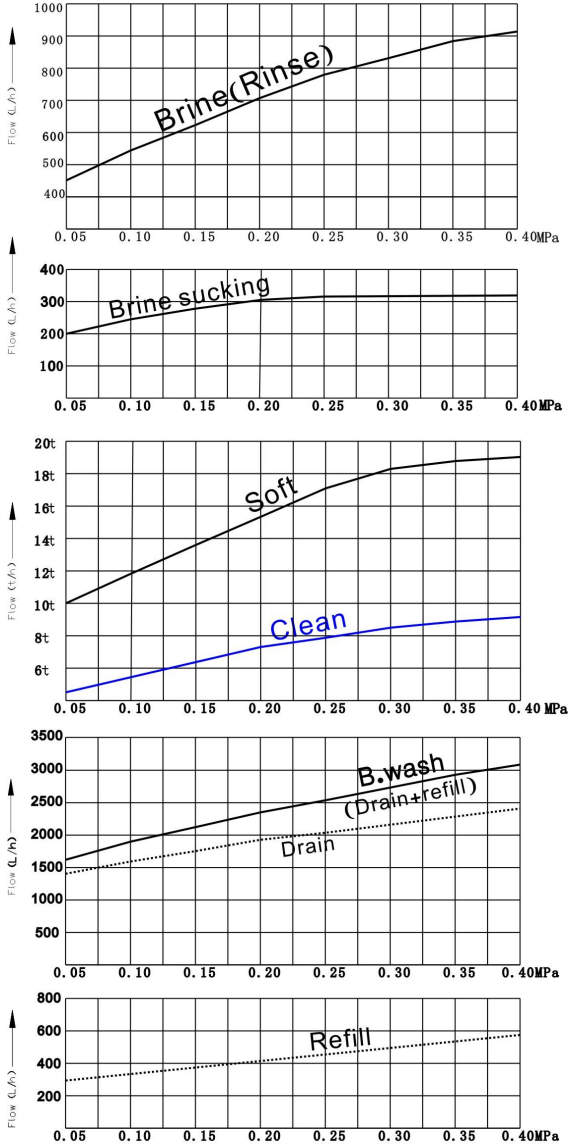

GR10-1D

Pic16: GR10-1D\GR10-1DS Flow and Pressure curve

VIII. Tips and Precautions for Equipment

Produced water is not qualified

Phenomena/reasons	Solution
No salt particle in the brine tank	Add salt to the brine tank
No enough absorption of salt water	Increase refilling water amount of  setting value
Flow rate is too large, running velocity is too high	Reduce the pressure difference between the inflow and outflow

Brine water leaking out to the water outlet

Phenomena/reasons	Solution
Insufficient amount of washing	Increase wash value to extended wash time
No enough resin and too much space at the top of the swap tank	Add more resin or other to reduce the space

The inlet pressure of the equipment increases and the water output decreases

Phenomena/reasons	Solution
Resin's being polluted by the suspended matter	Forced backwash or Unload the valve and wash the resin both inside and outside the tank.
Strainer is blocked by broken resin	Unload the Strainer and clean it.
Out pipes system have closure phenomenon	Check and eliminate the problem

The salt tank overflowed

Phenomena/reasons	Solutions
 Station setting is too large or the salt tank is too small	Reduce the set value, or increase the salt tank

No brine absorption

Phenomena	Reasons and Solution
Drainage pipe have water out,but no brine absorption	Water distributor inside the exchange tank is blocked, resin is contaminated, or there is interception in the drainage pipe system,
No water out from drain pipe,also no brine absorption.	Mainly is the jet nozzle blocked.

IX. Tips and Precautions of Equipment

1. Add salt to salt tank

The equipment should use large particles industrial salt. If some fine salt is used, please keep it at small amount. Otherwise, it will get agglomerated, leak to the salt filter and clog the tube.

2. Clean salt tank

The bottom of the salt tank needs to be checked frequently; the deposit and sludge need to be cleared out.

3. Clean inflow filter

The filter of inflow needs to be cleaned periodically in case that the inflow clogs the tubes and leads to low efficiency of the equipment as well as the decrease of the outflow amount.

X Control valve structure

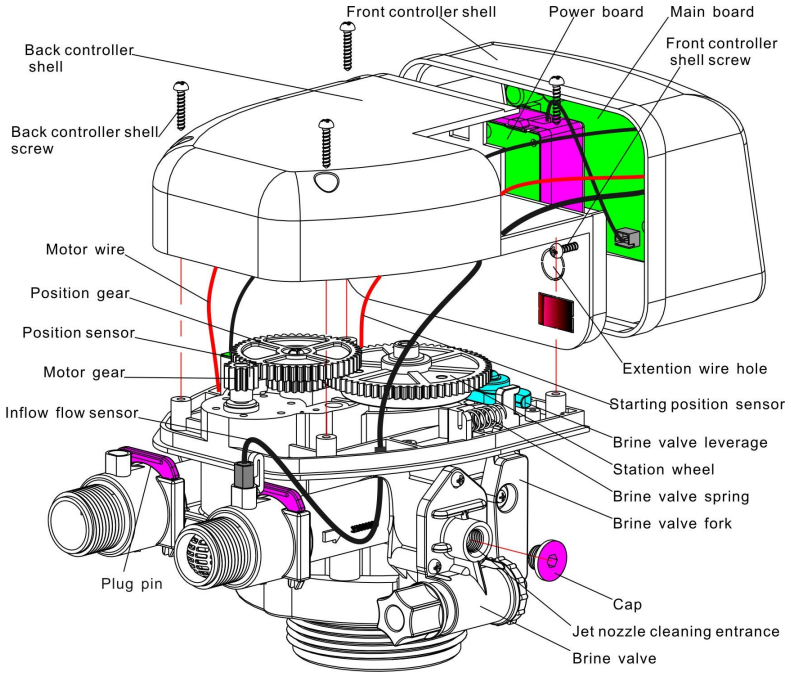

Pic17: Control valve structure(GR2-1D\GR4-1D)

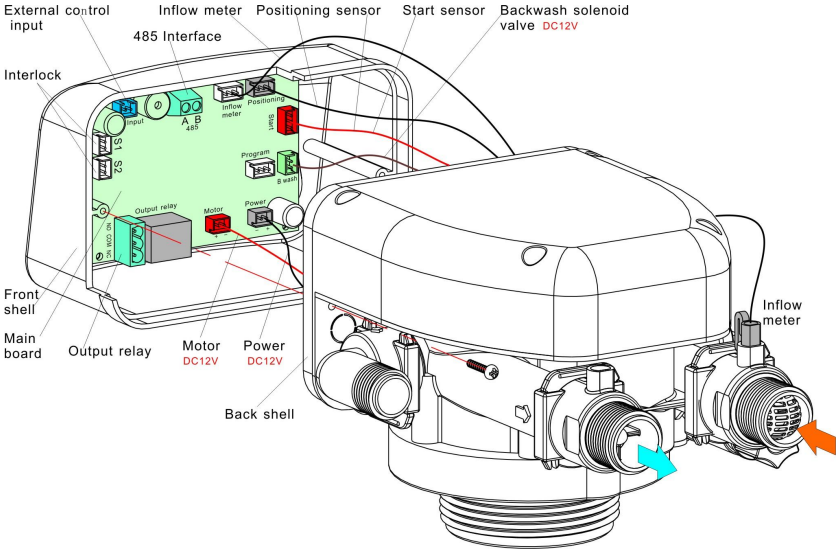

Pic18: Controller front shell disassembly(GR2-1D\GR4-1D)

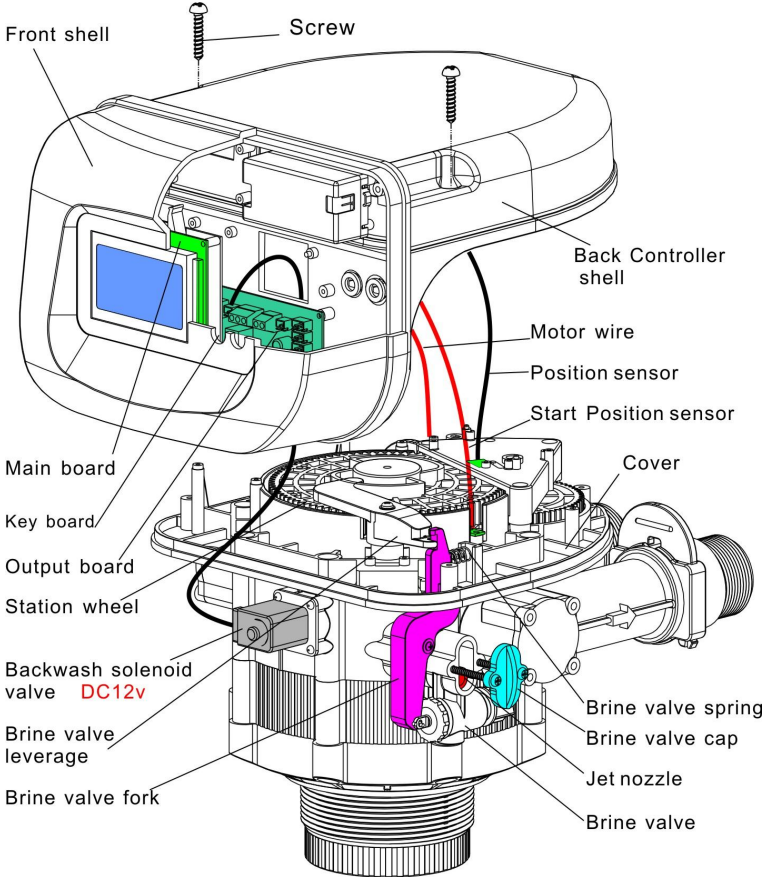

Pic19: GR10-1D Control valve structure

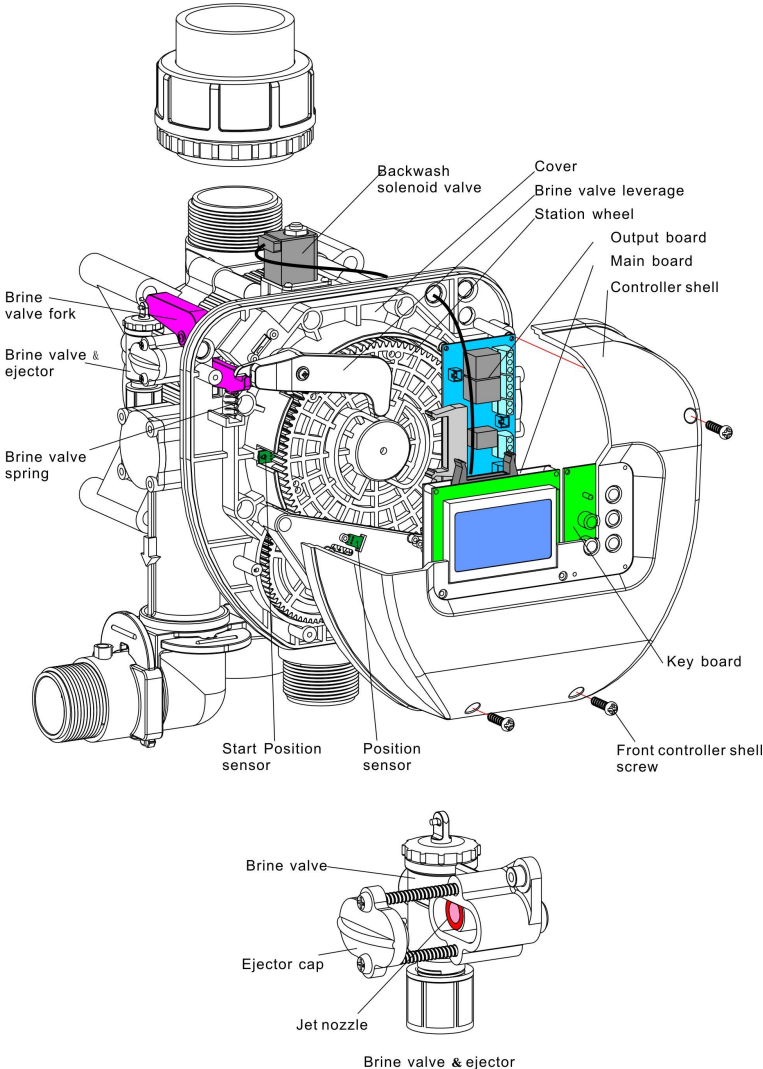

Pic20: GR10-1DS Control valve structure

XI、Explode drawing (GR4-1D example)

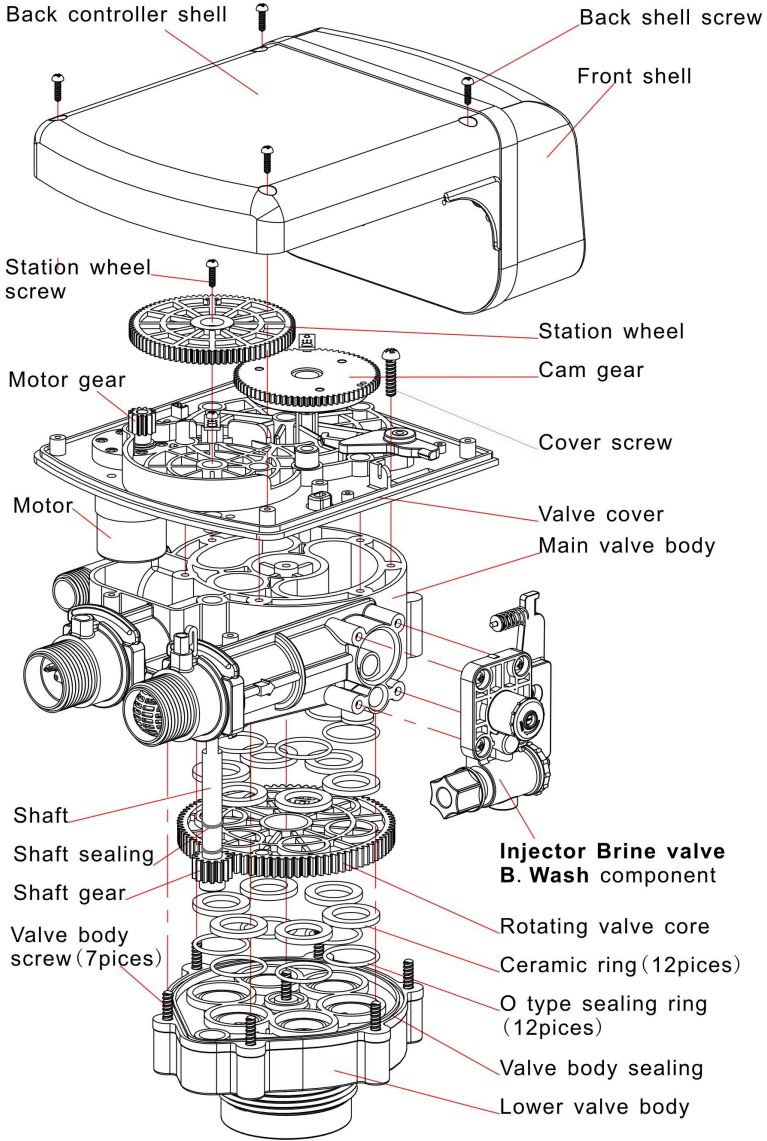

Pic21:Explode drawing (GR4-1D example)

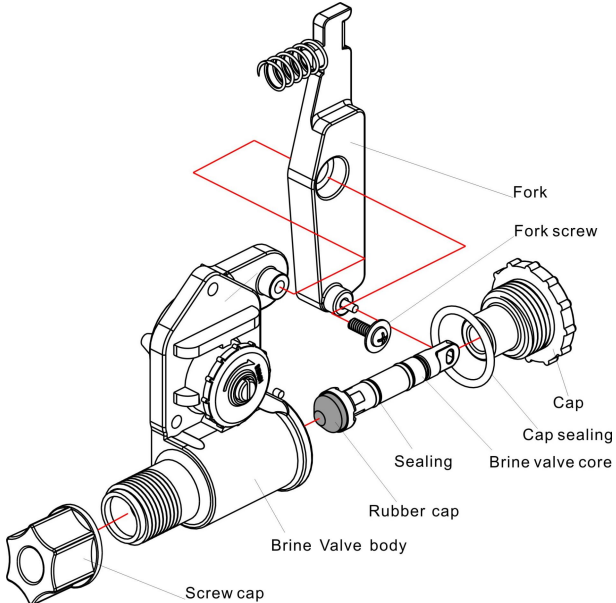

Pic22:Brine valve explode drawing (GR2-1D example)